

ASSEMBLY AND INSTALLATION INSTRUCTIONS FOR ITEM # A-WB (Workbench)

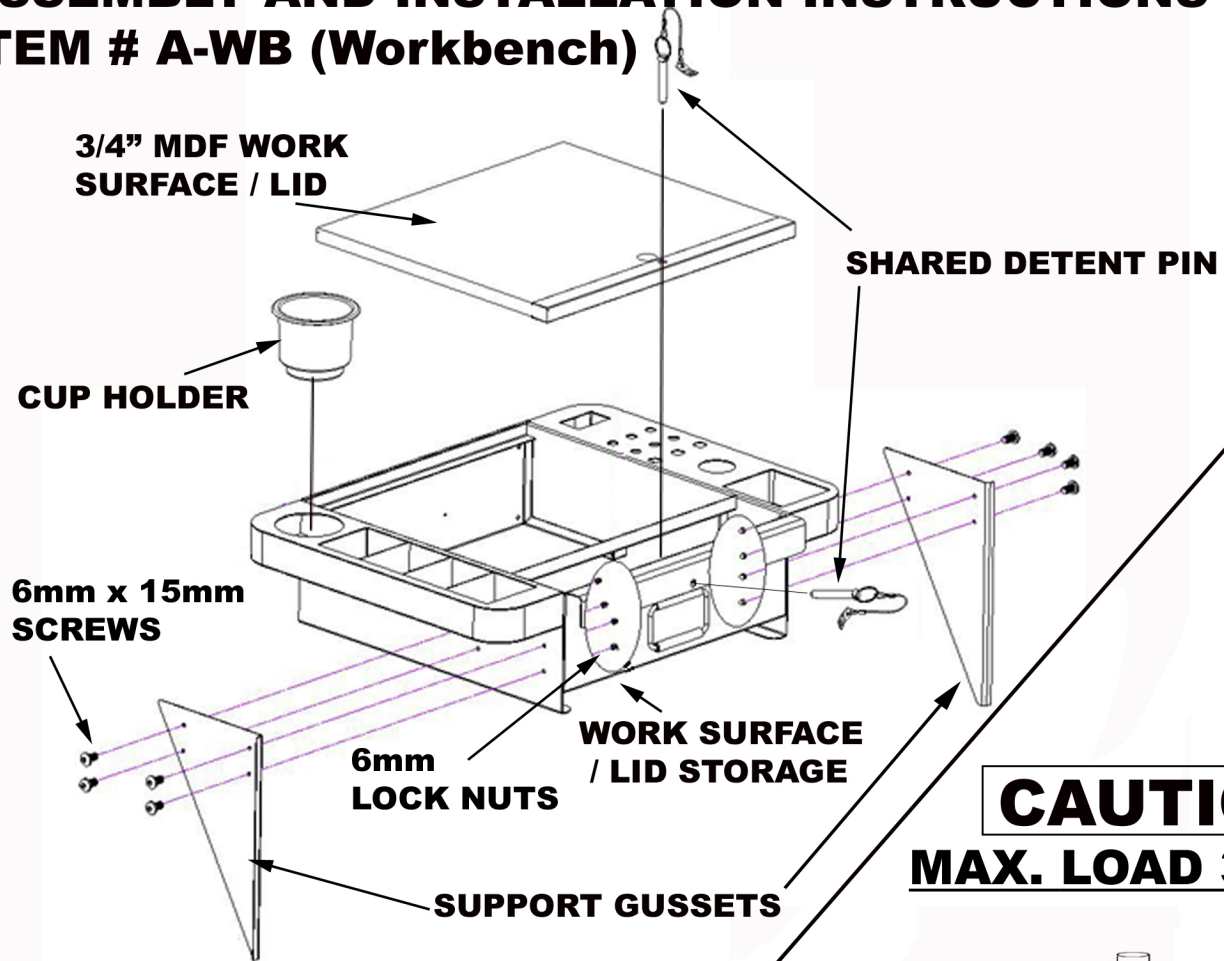

ASSEMBLY

- 1) Secure the two support gussets to the workbench using the eight 6mm screws and lock nuts provided. Make certain the flanges found on the support gussets are positioned away from the workbench.
- 2) The work surface/lid may be installed on top to cover the storage area or may be stored underneath when not in use.

INSTALLATION

- 1) Place C channel mounting bracket onto the rung of the end frame. (fits over all 1" rungs)
- 2) Make certain the attached detent pin is fully inserted through the C channel mounting bracket to secure workbench to the rung.
- 3) The detent pin may be used to hold the lid closed during transport or a padlock may be inserted through the hole found in the lid for additional security, on or off the job.

