

ASSEMBLY AND INSTALLATION INSTRUCTIONS FOR ITEM # A-1G (1 Gallon Paint Holder)

Fits all 1 1/2" square end frames

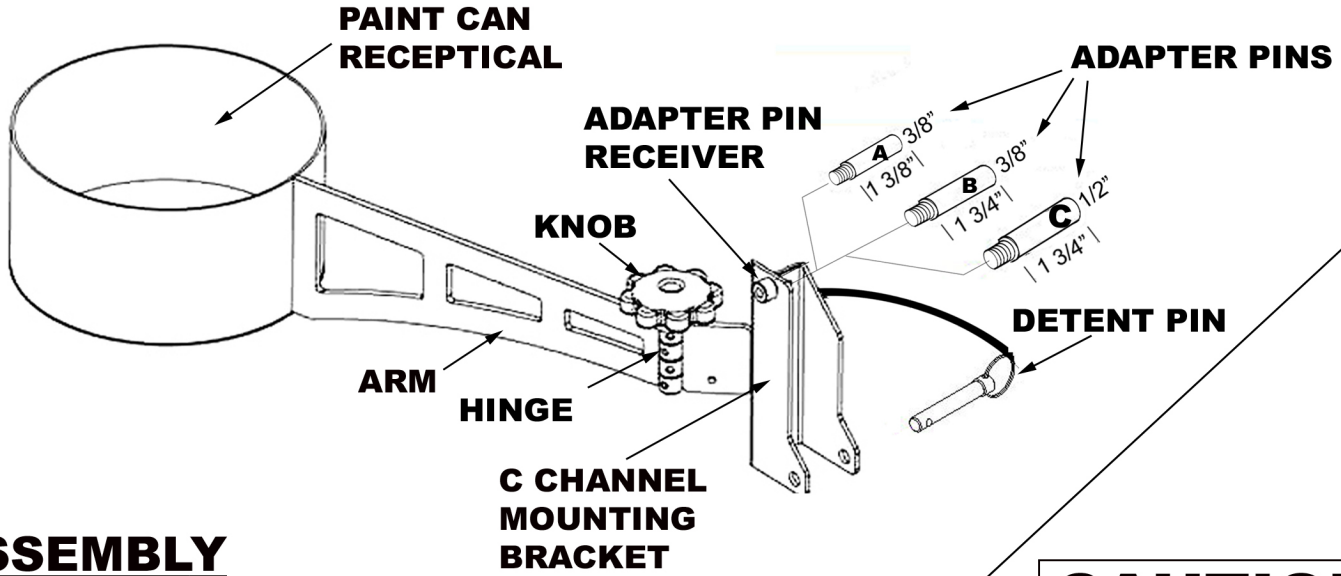

ASSEMBLY

- 1) Using the chart below, select the proper adapter pin for the type of scaffold being used.

A	3/8" x 1 3/8"	Scaffolds with 3/8" holes on only one side of the end frame Example (Perry)
B	3/8" X 1 3/4"	Scaffolds with 3/8" holes on both sides of the end frame Example (Grabber)
C	1/2 X 1 3/4"	Scaffolds with 1/2" holes on both side of the end frame Example (Crawler, Bil-Jax, Buffalo)

- 2) Thread the correct pin into the adapter pin receiver and tighten, using the 5mm Allen wrench supplied.

CAUTION
MAX. LOAD 20 LBS.

INSTALLATION

- 1) Raise the paint holder at an approx. 45° angle to the end frame while inserting the adapter pin through the holes of the end frame.
- 2) Lower the paint holder allowing the C channel mounting bracket to set into the square tube of the end frame.
- 3) Insert the attached detent pin through the holes found at the bottom of the mounting bracket, to secure the Paint Holder. (The detent pin may be replaced by a padlock for additional security)
- 4) Turn the knob counter-clockwise to adjust the position of the bucket. After the desired position is located, tighten knob by turning clockwise.

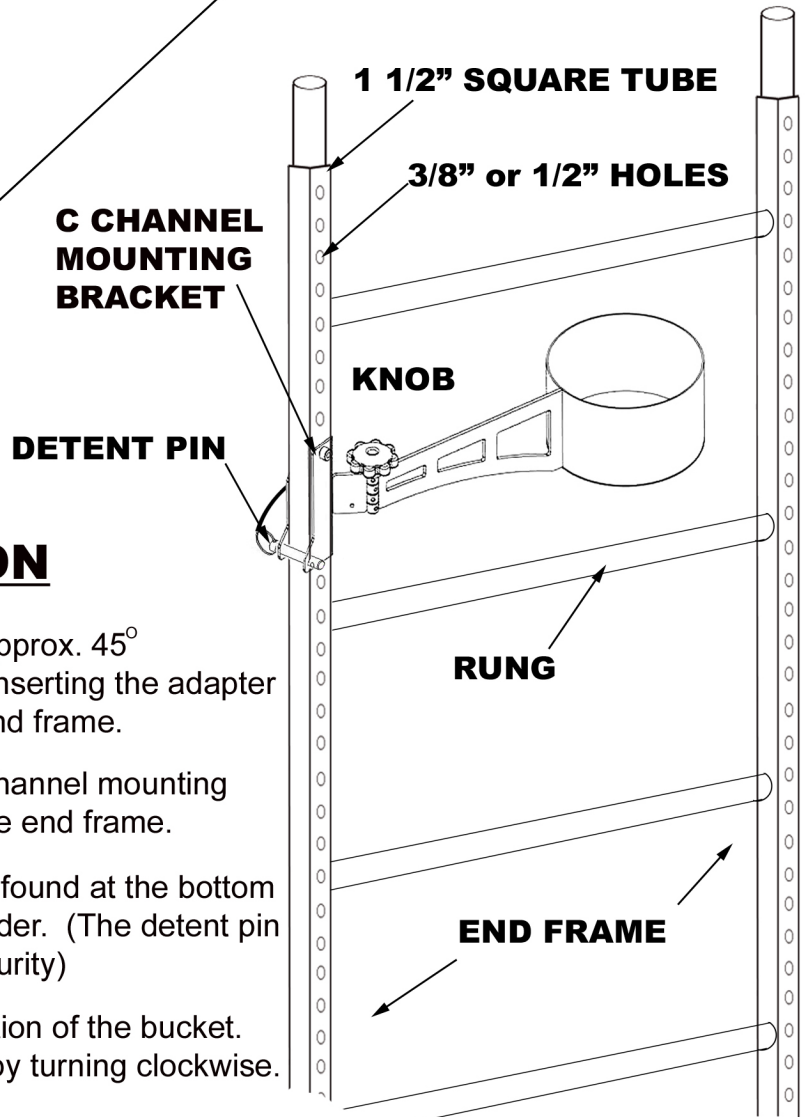

For more information visit: www.crawlerproducts.com